

Trolley Tip - Model Trolley Power Supply - by Fred Weigle

4/6 AMPERE REGULATED VOLTAGE POWER SUPPLY

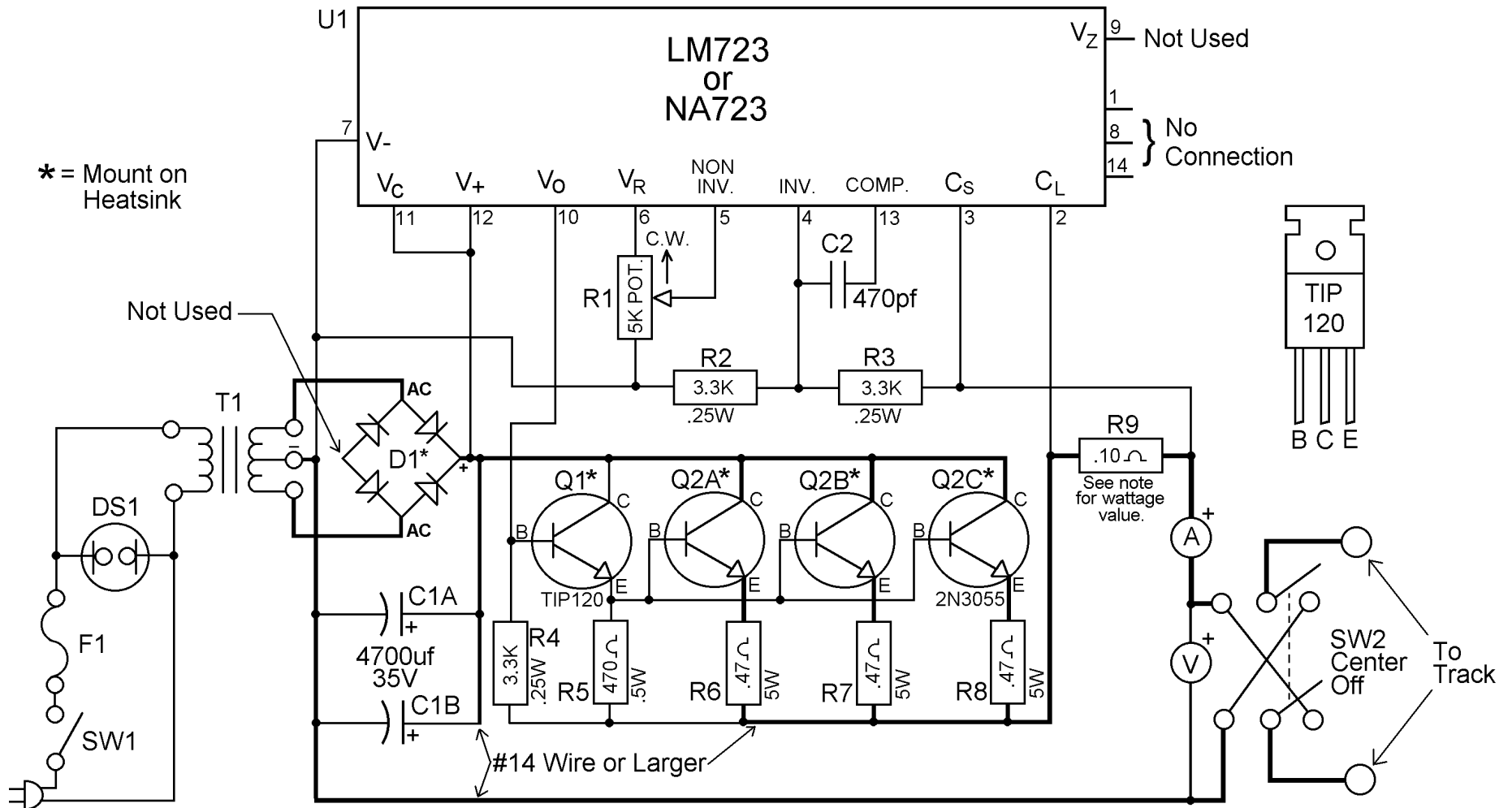

F. Weigle
5-12-94

REGULATED POWER SUPPLY PARTS LIST

Updated 4-11-97

		All Electronics Corp	Radio Shack	Hosfelt Electronics Inc.
T1	24 Volt C.T. 5 amp.	TX-245		56-438, 56-194, 56-195
D1	25 amp. 50 PIV Bridge	FWB-250	276-1185	
D1	15 amp. 200 PIV Bridge			KBPC1502
C1A & C1B	4700 uf. 35v Capacitor	4700 MFD-35V	272-1022	15-545 or 15-546
C2	470 pf. 50v Capacitor	DCMP-470	272-125	15-303
R1	5K Linear Potentiometer	NLTP-470	271-1714	CM46434
R2, R3 & R4	3.3K, .25W Resistor	3.3K-.25W	271-1328	QW233
R5	470 Ohm .5W Resistor	470 Ohm-.5W	271-1115	HW147
R6, R7 & R8	0.47 Ohm. 5W Resistor	0.47 Ohm-5W	271-130	5W-.47
R9 (4 Amp sup.)	0.15 Ohm 5W Res.			5W-.27 & 2W-.39 in par.
R9 (6 Amp sup.)	0.10 Ohm 5W	See note below.	5W-.1	
U1	LM723 Reg. I.C., I.C. Socket	LM723 ICS-14	276-1740 276-1999	LM723CN 21-266
Q1	TIP120 Transistor Heat Sink	TIP120 HS222	276-2068 276-1363	TIP120 36-434
Q2A, B & C	2N3055 Transistor Heat Sink	2N3055 HSPT-31	276-2041	2N3055 26-195
SW1	SPST Switch	STS-42	275-602	51-379
SW2	DPDT Switch Center Off	STS-8	275-1533	51-225
F1	2A Slow Blow Fuse Fuse Holder Line Cord	FS-2 FHPM-31 LCAC-19	270-1023 270-364 278-1255	31-798 43-202 60-250
DS1	Panel Lamp		272-707	

- Use 24 V. C.T. transformer for up to 9 Amps. This transformer may not deliver full 12 volts at full current, but at 9 volts will regulate at full current. If full 12 volts at full current is desired, find a transformer that will deliver full desired current at 17 volts rms.
- Omit transistor Q2C and Resistor R8 for 4 amp supply.
- Meters and miscellaneous hardware are up to builder.

Note: If a maximum current limit other than 4 or 6 amps is desired, the calculation for R9 is: (0.63) divided by the desired current limit. Example: (0.63) divided by 5 Amp. = 0.125 Ohm. You could use 0.22 Ohm and 0.33 Ohm in parallel. This would limit the current at about 4.77 amps.

All Electronics Corp.
P.O. Box 567
Van Nuys, CA 91408-0567
1-800-826-5432
www.allcorp.com

Jameco
1355 Shoreway Rd.
Belmont, CA 94002-4100
1-800-831-4242

Digi-Key Corp.
701 Brooks Ave. South

P.O. Box 677
Thief River Falls, MN 56701-0677
1-800-344-4539

Hosfelt Electronics, Inc.
2700 Sunset Blvd.
Steubenville, OH 43952-1158
1-800-524-6464

Mouser Electronics
2401 Highway 287 North
Mansfield, TX 76063-4827
1-800-346-6873

F. Weigle
4-11-97

East Penn Traction Club